



Combined Yak52 & Intermediate World Aerobatic Championships

Bulletin No. 2

November 26th through December 3rd, 2014

**Mossel Bay Airport
Western Cape Province
Republic of South Africa**

Website: www.yakwac2014.co.za

1. General

The FAI Combined Yak52 & Intermediate World Aerobatic Championships 2014 is organised by the Aerobatic Section (Sport Aerobatic Club) of the Aero Club of South Africa, in cooperation with the Mossel Bay Aero Club and the Mossel Bay Municipality. Although both Yak52 & Intermediate will be flown together with the same set of officials, the competitions are in fact separate each with it's own set of results, champions etc. Further details are outlined in section 4 of the CIVA Regulations.

The Previous restriction of fifty-five pilots preliminary entry has now been removed and the contest will go-ahead regardless of the number of entrants, this previous restriction had probably led to some reluctance by Aero Clubs to commit to the contest.

1.1 Venue

The 1st Combined Yak52 & Intermediate World Aerobatic Championships will be held at the Mossel Bay Airfield, situated in the Western Cape of South Africa. Mossel Bay is situated along the renowned Garden Route, a favourite tourist attraction in the Western Cape it is 392km east from Cape Town, 396km west from Port Elizabeth & 1, 250km south from Johannesburg. It is served by the Regional Airport at George, which is 40km from Mossel Bay.

A full description of Mossel Bay can be found on www.visitmosselbay.co.za

Basic details of Airfield, the aerobatic box will be immediately to the North of the airfield.

Mosselbay
FAMO
AEROBATIC (SAC)

Airfield Info

34°09'25" S
022°03'41" E

ELEV 526 FT AMSL

Tower - 120.20 MHz

ATNS

Runway: 09/27- 1126 x 18m (ASPH)
Runway edge lights and THR lights.
Daylight switch.

Airspace: ATC Class "C"

Vertical limits: GND/3500 FT AMSL (3000' AGL)

Lateral limits: Circle radius 5 NM centered at S34°09'25" E 022°03'41" (R266 GRV 18DME)

Circuit Alt: 2000' ALT (1500' AGL)

Call Sign: Mosselbay Tower

Tower HOS: 27 - 29 Sept 2012
06:00Z - 16:00Z

NOTE:
Delays may be expected to non participating aircraft
Located in high density area beware of unnecessary low flying.
Beware of model flying just north of threshold RWY 27.



Imagery is for reference only

Valid for 27 - 29 Sept 2012 ONLY

Non Official Chart

2. Contest Officials

2.1 International Jury

Jury President: Lars-Goran Arvidsson

Jury Members: Elena Klimovich

Alan Cassidy

2.2 Board of Judges

Chief Judge – Pavol Kafka

Judges – Will be announced once the selection process has taken place, but no later than 1st August 2014.

2.3 Organising Body – Sport Aerobatic Club of South Africa (SAC)

Contest Director - John Gaillard

2.4 Officiating Body – Sport Aerobatic Club of South Africa (SAC)

Contest Director – John Gaillard

Assistant Contest Director - To be advised

Flight Director - To be advised

2.5 Technical Commission

To be advised

3. Schedule

26th November	10:00 to 17:00 -	Arrivals
	17:30 to 18:30 -	General Briefing
	18:45 to 19:45 -	Judges Briefing
	20:00 to 22:00 -	Opening Ceremony
27 th November	08:00 to 08:30 -	Daily Briefing
	09:00 to 20:00 -	Competition Flights Programme 1 (40 flights)
28 th November	08:00 to 08:30 -	Daily Briefing
	09:00 to 13:00 -	Competition Flights Programme 1 (20 flights)
	14:00 to 15:00 -	Selection of Unknown figures – Programmes 3 & 4
	15:30 to 20:00 -	Competition Flights Programme 2 (30 flights)
29 th November	08:00 to 08:30 -	Daily Briefing
	09:00 to 14:00 -	Competition Flights Programme 2 (30 flights)
	15:00 to 20:00 -	Competition Flights Programme 3 (30 flights)
30 th November	08:00 to 08:30 -	Daily Briefing
	09:00 to 13:00 -	Competition Flights Programme 3 (30 flights)
	14:00 to 20:00 -	Competition Flights Programme 4 (30 flights)
1 st December	08:00 to 08:30 -	Daily Briefing
	09:00 to 13:00 -	Competition Flights Programme 4 (30 flights)
	14:00 to 20:00 -	Weather delay allowance
2 nd December	08:00 to 08:30 -	Daily Briefing
	09:00 to 14:00 -	Weather delay allowance
	18:00 to 21:00 -	Closing Ceremony
3 rd December	08:00 to 14:00 -	Departures

4. Regulations

4.1 General

The combined Yak52 & Intermediate World Aerobatic Championships will be organised in accordance with the following: -

- FAI Sporting Code – General Section
- FAI Sporting Code – Section 6, part 1, version 2014
- Aresti Catalogue (condensed) for Power Aerobatics
- Regulations issued by the Recreational Aviation Administration South Africa (RAASA)
- South Africa Civil Aviation Regulations (SACAA)

4.2 Combined Operational Regulations

- All briefings will take place together without separation between Yak52 & Intermediate contests
- Flight order will be determined by the drawing of lots without separation between the Yak52 & Intermediate contests
- The selection of figures for the Free-Unknown Programmes will take place separately between the Yak52 & Intermediate contests and sequences determined separately per contest, thereafter flight order will be determined jointly
- Contest results will be published separately, there will be no combined Yak52 & Intermediate contest results
- Judging Analysis will be determined and published separately for Yak52 & Intermediate
- Separate National Teams may be entered for Yak52 & Intermediate Contests
- For the purpose of opening and closing ceremonies, National Teams will be combined, Prize giving will be held jointly

5. Participation, Competitors and Aircraft

5.1 Participants

- 5.1.1 NAC Entries - All FAI member National Airsport Controls (NACs) may be represented at the combined Yak52 and Intermediate World Aerobatic Championships by a team and/or individual competitors and observers.
- 5.1.2 Non – NAC Entries – The Organisers will accept entries in accordance to the FAI Sporting Code – Section 6 as “Hors Concours” (H/C). The Organisers require HC entries to provide evidence of appropriate and current aerobatic experience in the championship entered.
- 5.1.3 All Competitors must: -
 - a) Be members of their appropriate National Airsport Controls (NAC)
 - b) Be in possession of an FAI Sporting Licence
 - c) Hold a valid pilots licence with authorisation for aerobatics
 - d) Hold a valid medical certificate
 - e) Hold a valid personal insurance policyAll such documents shall be presented upon registration for the contest

5.2 Aircraft

- 5.2.1 Each participating aircraft must have a valid Certificate of Airworthiness or Permit to fly, valid for aerobatic flight, in accordance with the FAI Sporting Code 1.2.6.1.
- 5.2.2 Each aircraft must have a Certificate of Insurance against Third Party legal Liability (equivalent one million USD); this certificate must cover the aircraft for use in aerobatic competition.

5.3 Fuel

Fuel will be supplied by the Organiser for Competition Flights.

5.4. Team Composition

5.4.1 – Competitors

Team composition will be in accordance to the Sporting Code, Section 6; part 1, separate Teams shall be entered for Yak52 and Intermediate.

5.4.2 – Officials

Officials as defined in the FAI Sporting Code Section 6, may enter as National Team Members, Team Members may be shared between Yak52 & Intermediate entries from the same NAC, i.e. one entry fee for officials even if representing both Teams.

- 5.4.3 – The relatives or other associates of competitors are accepted as Observers for the National Team or Teams as per 5.4.2 above.

6. Entry Fees

All Competitors, Team Members & Observers

Payment Date

Early	– Before 1 st September 2014	–	Euro 1, 200
Regular	– Before 15 th October 2014	-	Euro 1, 300
Late	- After 15 th October	-	Euro 1, 400

Entry Fees Covers:

All persons – Shared accommodation between the nights of 26th November to 2nd December, 3 meals per day, transfers between George Regional Airport, daily transfers between accommodation and Mossel Bay Airport. FAI Sanction fee where appropriate.

Single supplement of Euro 20 per night if specifically requested.

Competitors – Fuel for competition flights

Special Conditions for Yak52 Competitors – The first three entries per National Aero Club (or as defined by the Aero Club concerned) will be provided with a Yak52 aircraft free of charge, including one hours free practice, subject to being on site by 26th November or before.

7. Local Aircraft Availability

Up to eight Yak52s will be available on site, these may be hired. In addition for the Intermediate Championship there is a variety of aircraft available to hire, including Pitts Specials, Yak 55, Zlin 50, Super Decathlon, Slick 360 (a locally produced unlimited aircraft), and Extras etc. The list is currently being finalised, together with hire rates, enquiries can be made to SAC Club Secretary Annie Boon chunge@mweb.co.za

8. Accommodation

All competitors, judges & officials will be accommodated at the Diaz Strand Hotel, a 3 star Hotel which is a prime tourist venue, being directly on the Indian Ocean beach and with all the facilities associated with such establishments. Check it out on www.hotel.co.za/mossel-bay-diaz-strand.html

Daily briefings will take place in the Hotel Conference facility and an hourly shuttle will be available to the airfield, which is about a 15 minute trip. Competitors and their families will therefore have the opportunity to relax in a World class holiday facility, so families are welcome without fear of being bored on an airfield, an ideal opportunity to combine a family holiday with competition aerobatics and get away from the Northern Hemisphere winter.



The Organisers can also arrange to put you in touch with a suitable travel agent should persons wish to extend their stay in South Africa.

9. Training Flights

The airfield at Mossel Bay will be made available for seven days prior to the commencement of the Championship for training flights, slots will be bookable via the contest website nearer to the time of the contest, and the website will be operational by 1st August.

A special package for accommodation will be made available by the Organiser for practice before the competition, this accommodation must be booked through the Organiser, the rates will be Euro 40 for a shared room and Euro 50 for a single room, Bed & Breakfast rate.

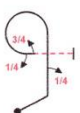
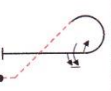
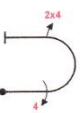
10. Known Compulsory Sequence

2014										Form A		
Pilot ID										Flight #		
Y52/Intermediate Known												
No	Symbol	Cat. No.	K	Total K	Example marks: 7 5 0 0 Zeros and Averages: HIZ PZ AV	Remarks	Pos	Item	K	Grade		
1		8.6.2.1 9.1.1.1 9.1.3.1 9.1.3.3	12	26				Positioning				
			6									
			2									
			6									
2		8.5.1.2 9.1.3.2 9.1.3.6	10	24					Fig K	Total K		
			4						179	179		
Penalties												
Too Low												
Disqual Fig												
Too High												
Outs												
Interruptions												
Insertions												
Missed Slot												
Trg Violation												
Faulty Wing Rocks												
Final Freestyle												
Duration										Min	Sec	
Judges Details												
Signature												
Name												
Number												
8		7.2.2.1 9.4.3.4 9.4.3.2	6	22								
			11									
			5									
9		2.1.3.1	14	14								

Created Using Aresti 2013™ software. ACCasido@aol.com



pilot
A/C



2014		FORM B
Pilot ID #	Y52/Intermediate Known	
	Flight #	

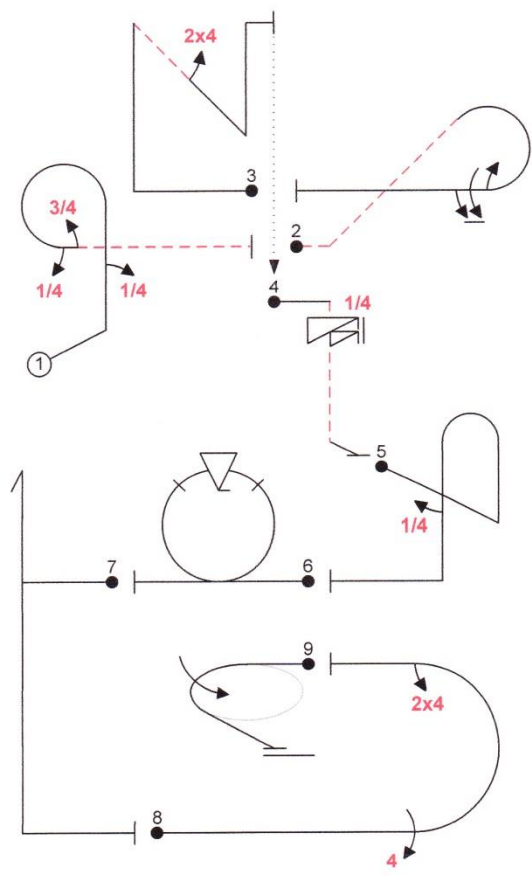
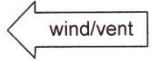
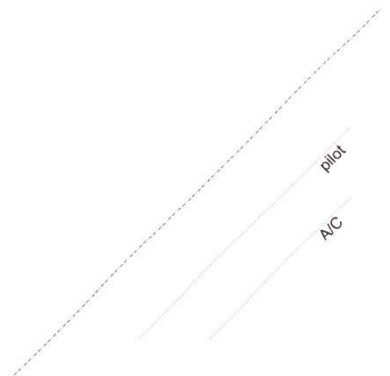

Fig 1	8.6.2.1	12	26
	9.1.1.1	6	
	9.1.3.1	2	
	9.1.3.3	6	
Fig 2	8.5.1.2	10	24
	9.1.3.2	4	
	9.1.3.6	10	
Fig 3	1.3.12.1	21	26
	9.4.4.2	5	
Fig 4	1.1.6.3	10	14
	9.11.1.5	4	
Fig 5	8.4.1.1	13	15
	9.1.5.1	2	
Fig 6	7.4.1.1	10	21
	9.9.3.4	11	
Fig 7	5.2.1.1	17	17
Fig 8	7.2.2.1	6	22
	9.4.3.4	11	
	9.4.3.2	5	
Fig 9	2.1.3.1	14	14
Total K = 179			

Created Using Aresti 2013™ software. ACCassidy@aol.com





		2014	FORM C
Pilot ID #	Y52/Intermediate Known		Flight #

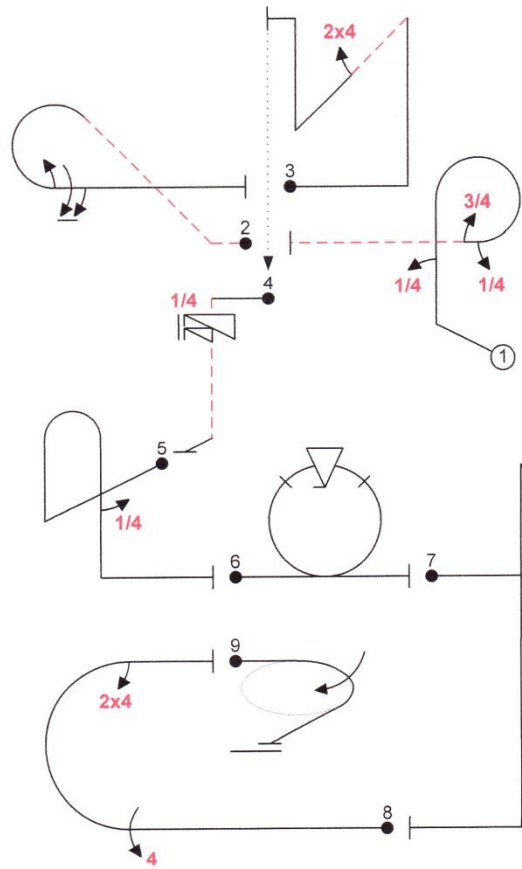
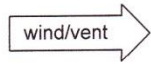

Created Using Aresti 2013™ software. ACCassidy@aol.com

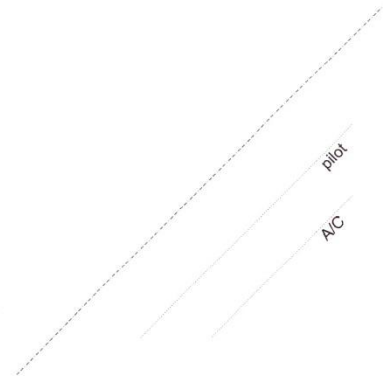



Entry Form

Combined Yak52 & Intermediate World Aerobatic Championships

National Aero Club.....

Number of Competitors Yak52.....

Number of Competitors Intermediate.....

Number of Additional Team Members.....

Number of Observers.....

Total Number in Delegation.....

Banking Details for Entry Fee as follows:-

Account Name: The Aero Club of South Africa Events (PTY) LTD

Name of Bank: First National Bank

Account Number: 62426989664

Branch: Hatfield 252145

Swift Number: FIRNZAJJXXX

IBAN: 252145

Contact Person Name.....

Contact Person e-mail.....

Contact Person Telephone.....

Please return to J L Gaillard at aeroair@iafrica.com please note that entry fees are only payable by 1st September, but entry form should be sent as early as possible.